

4

3

2

1

THIS DRAWING AND THE INFORMATION CONTAINED WITHIN IT ARE CONFIDENTIAL AND MAY NOT BE COPIED OR DISCLOSED WITHOUT THE WRITTEN PERMISSION OF BLUE SEA SYSTEMS.

REVISIONS				
ZONE	REV.	DESCRIPTION	DATE	APPROVED
	1	PRODUCTION RELEASE	2012.3.27	S. SCHANKEN
	3	DRAWING UPDATE TO SHOW CHANGE TO FLANGE NUTS	2014.7.8	S. SCHANKEN
	3	UPDATED TO STANDARDIZE NOTES. NO REVISION CHANGE	2015.8.31	S. SCHANKEN
	3	REMOVE TOLERANCE BLOCK, REFERENCE DIMENSIONS, CUSTOMER DRAWING	2023.04.13	T. DYKAS

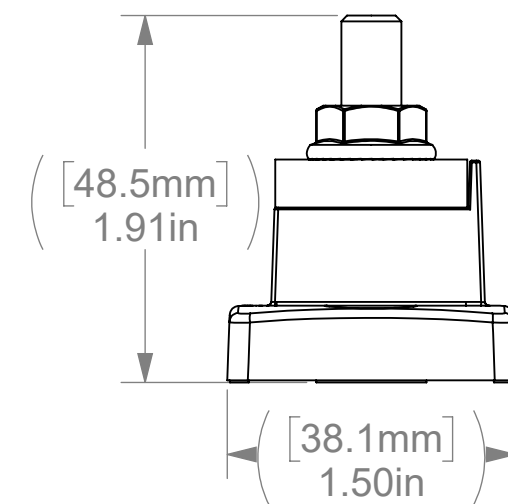
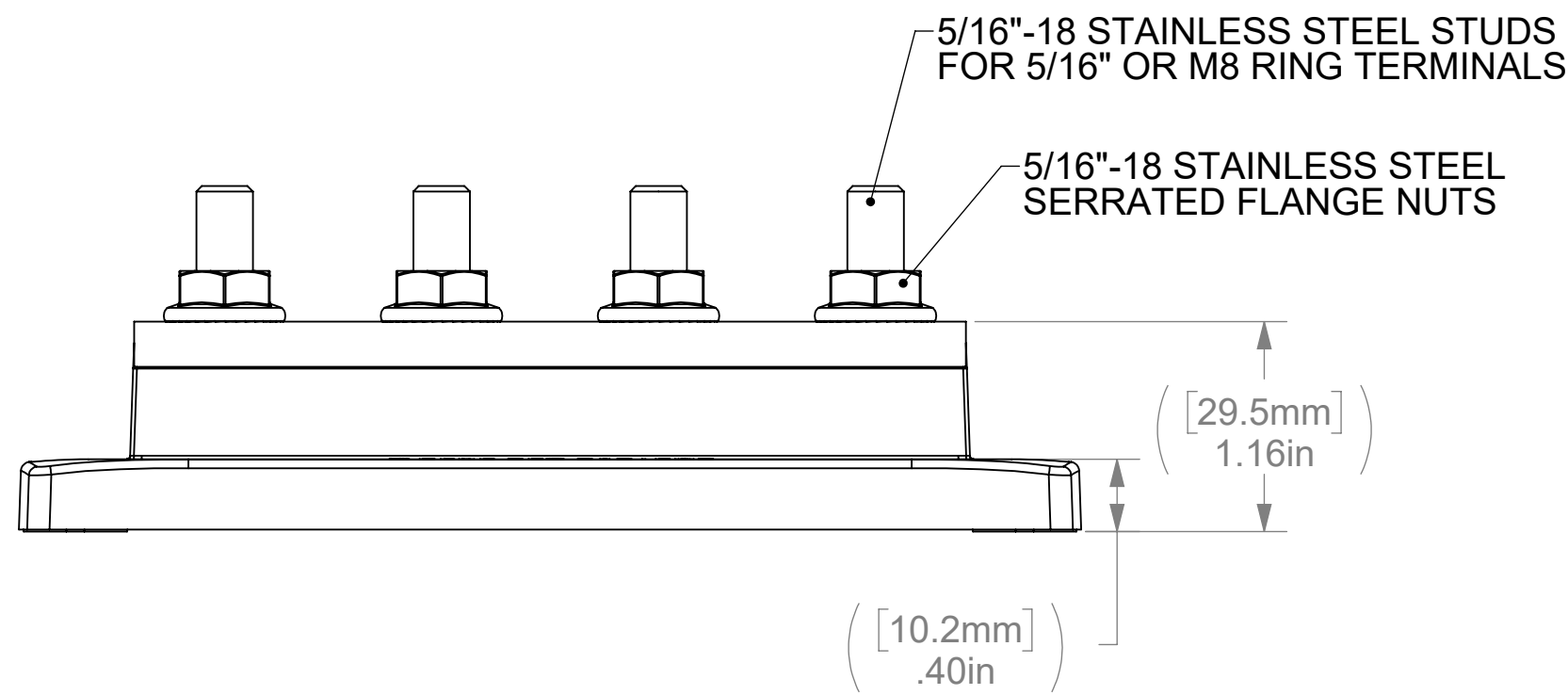
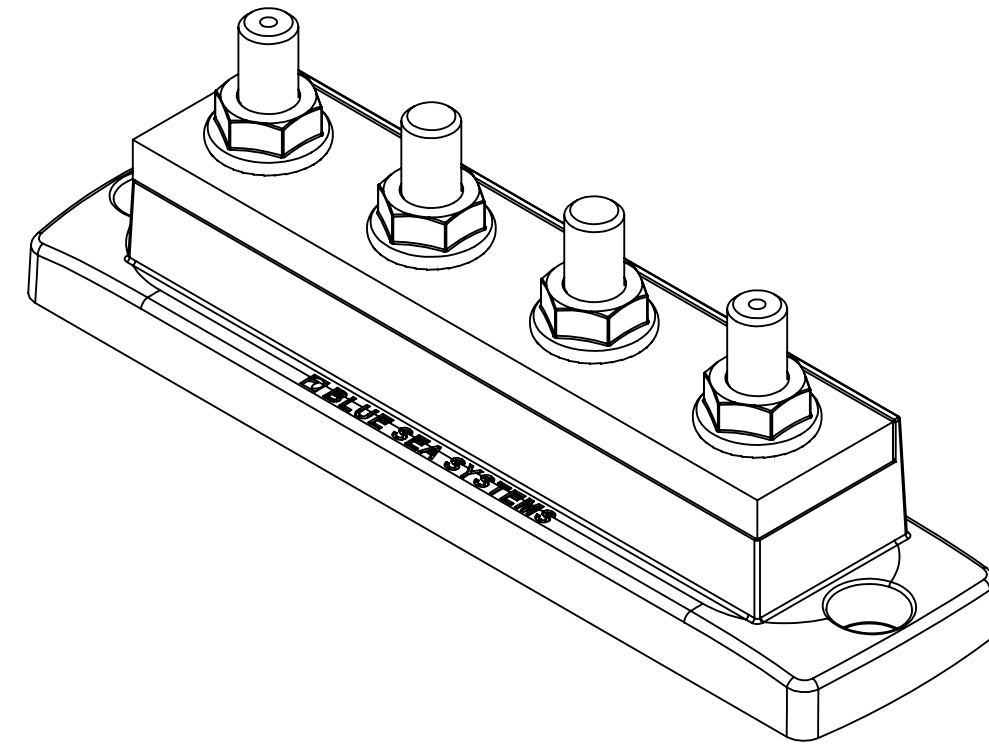
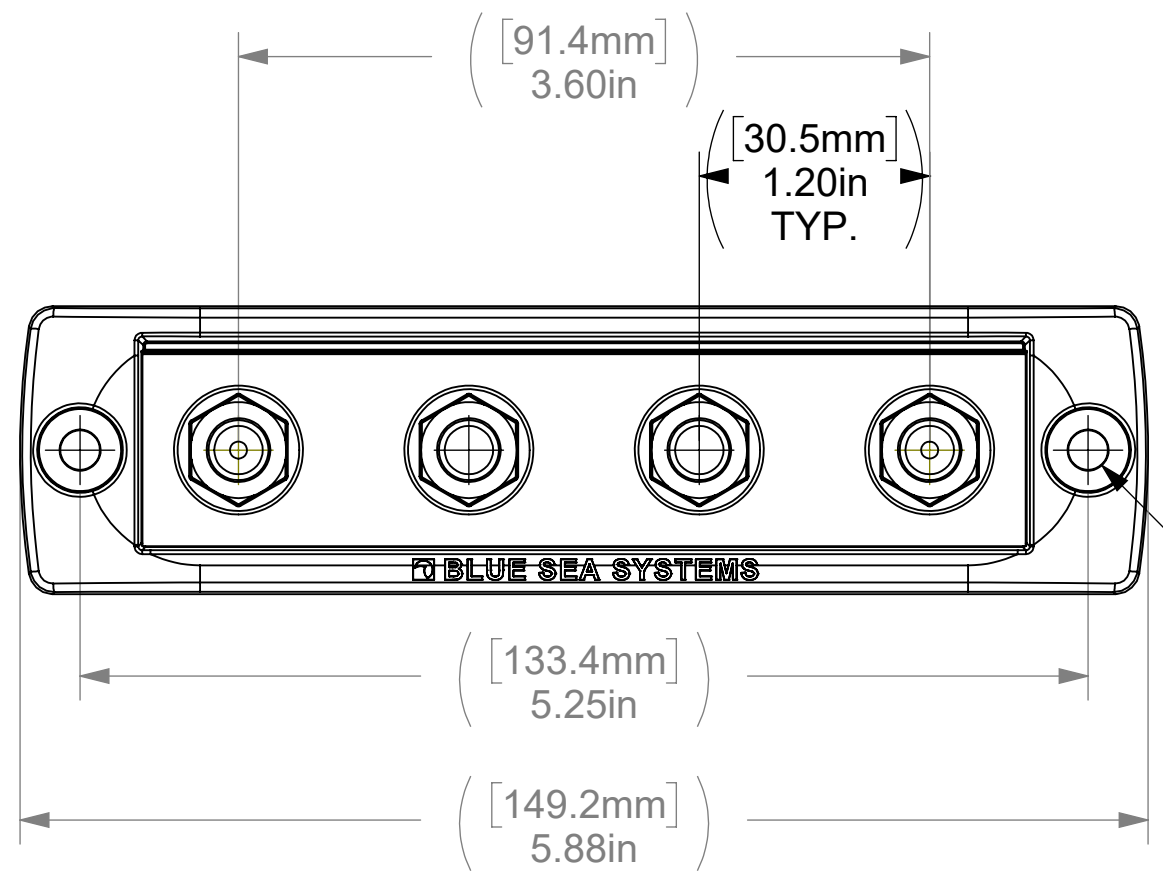

THIRD ANGLE PROJECTION



4

3

2

1

NAME	DATE
DRAWN T. DYKAS	2011.5.28
CHECKED J. RAU	2015.8.31
-	-
-	-
-	-

BLUE SEA SYSTEMS
 425 Sequoia Drive Bellingham, WA 98226
 Phone (360)738-8230 Fax (360)734-4195

CUSTOMER DRAWING
 MAXIbus 4 x 5/16 Stud Common New
 Part Number 2127

SIZE	DWG. NO.	REV.
C	2127	3
SCALE 1:1	WEIGHT: --	SHEET 1 OF 1