

4

3

2

1

THIS DRAWING AND THE INFORMATION CONTAINED WITHIN IT ARE CONFIDENTIAL AND MAY NOT BE COPIED OR DISCLOSED WITHOUT THE WRITTEN PERMISSION OF BLUE SEA SYSTEMS.

ZONE		REV.	DESCRIPTION	DATE	APPROVED
1		1	PRODUCTION RELEASE	2012.3.27	S. SCHANKEN
3		3	UPDATED TO SHOW SERRATED FLANGE NUTS	2015.8.31	S. SCHANKEN
3		3	REMOVE TOLERANCE BLOCK, REFERENCE DIMENSIONS, CUSTOMER DRAWING	2023.04.13	T. DYKAS

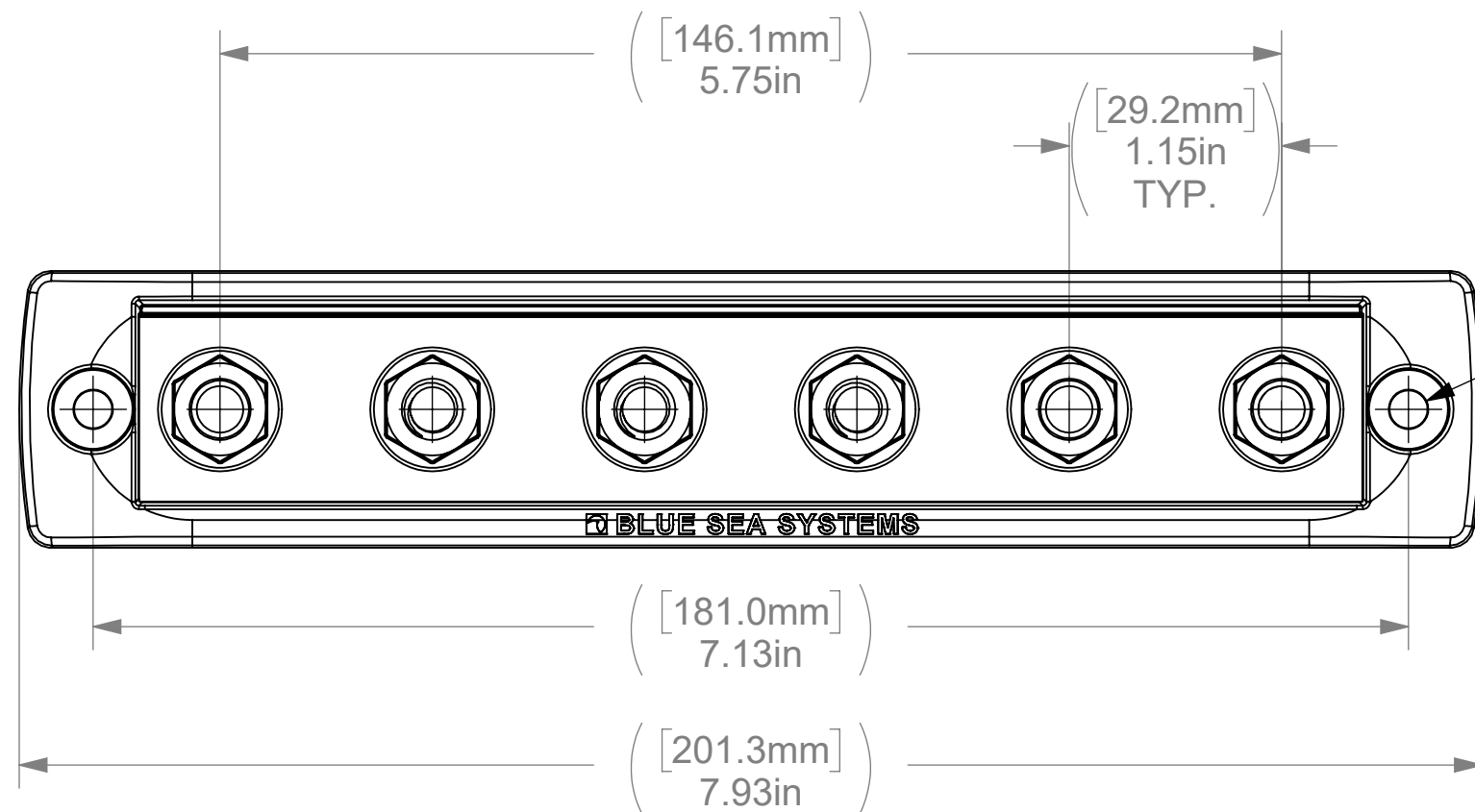

CLEARANCE FOR #10 OR M5 MOUNTING HARDWARE

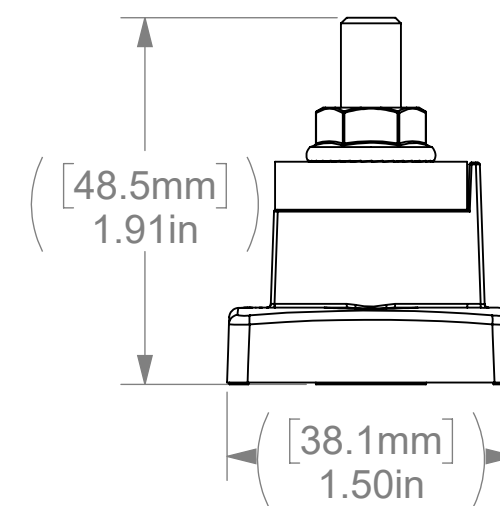
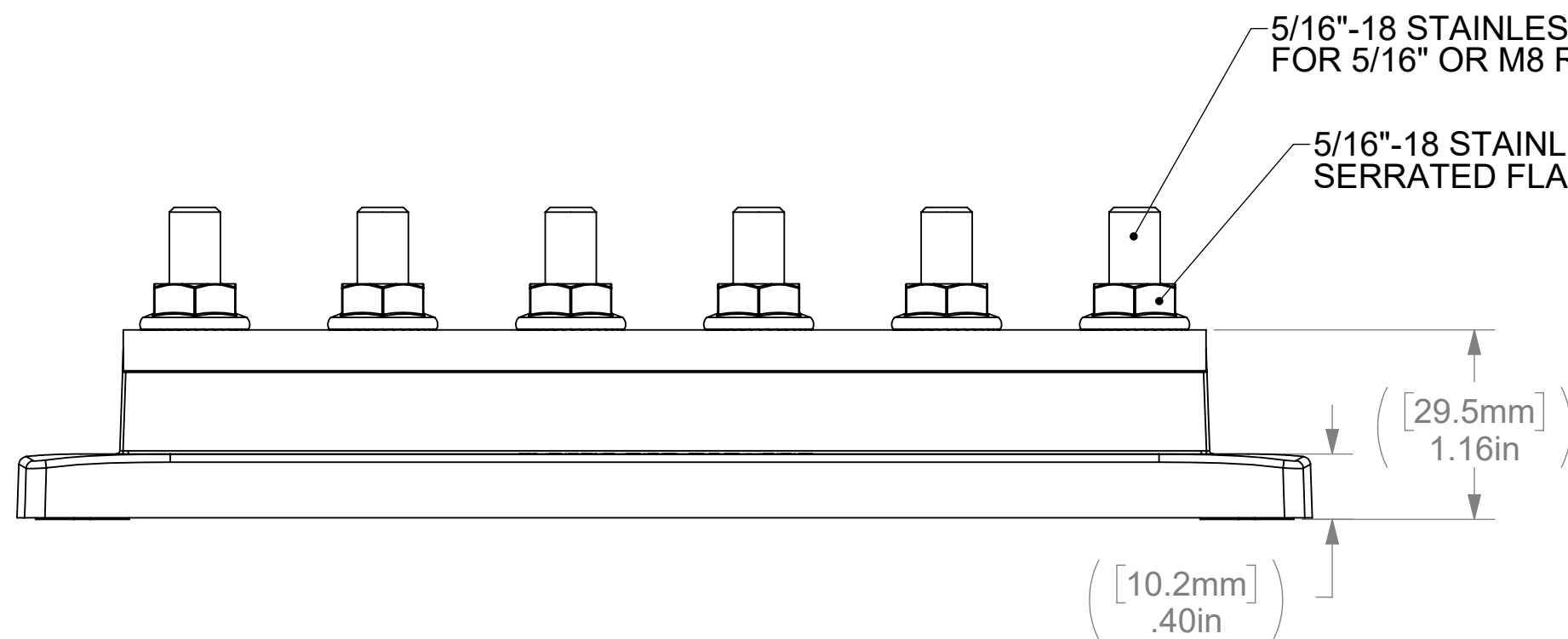
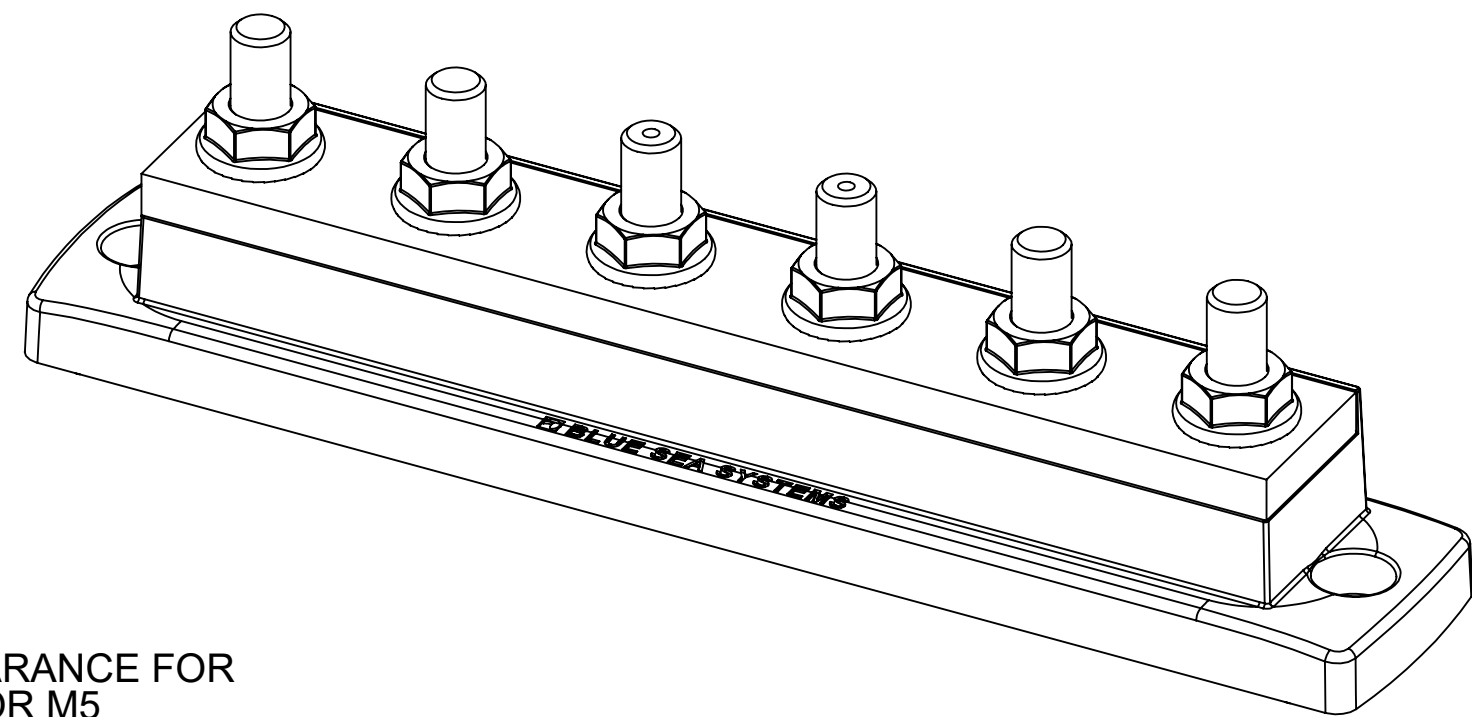

THIRD ANGLE PROJECTION



NAME	DATE
DRAWN T. DYKAS	2011.05.17
CHECKED J. RAU	2015.8.31
-	-
-	-
-	-

BLUE SEA SYSTEMS
 425 Sequoia Drive Bellingham, WA 98226
 Phone (360)738-8230 Fax (360)734-4195

CUSTOMER DRAWING
 MAXibus 6 x 5/16 Stud Common
 Part Number 2126

SIZE	DWG. NO.	REV.
C	2126	3
SCALE 1:1	WEIGHT: --	SHEET 1 OF 1

4

3

2

1