

4

3

2

1

THIS DRAWING AND THE INFORMATION CONTAINED WITHIN IT ARE CONFIDENTIAL AND MAY NOT BE COPIED OR DISCLOSED WITHOUT THE WRITTEN PERMISSION OF BLUE SEA SYSTEMS.

REVISIONS				
ZONE	REV	DESCRIPTION	DATE	APPROVED
	1	PRODUCTION RELEASE	2012.3.27	S. SCHANKEN
	3	UPDATED TO SHOW SERRATED FLANGE NUTS	2015.8.31	S. SCHANKEN
	3	REMOVE TOL BLOCK, REFERENCE DIMENSIONS, "CUSTOMER DRAWING"	2023.04.13	T. DYKAS

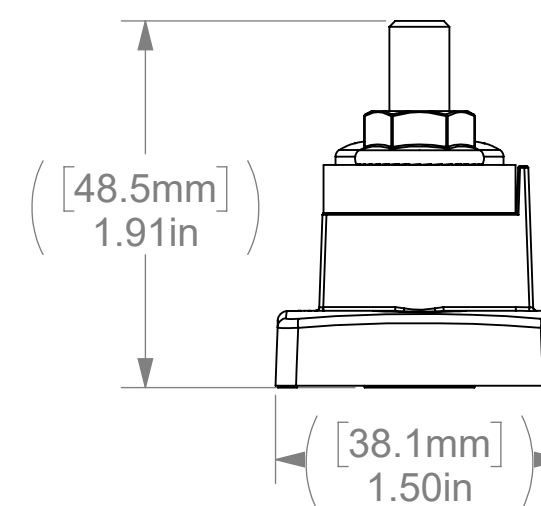
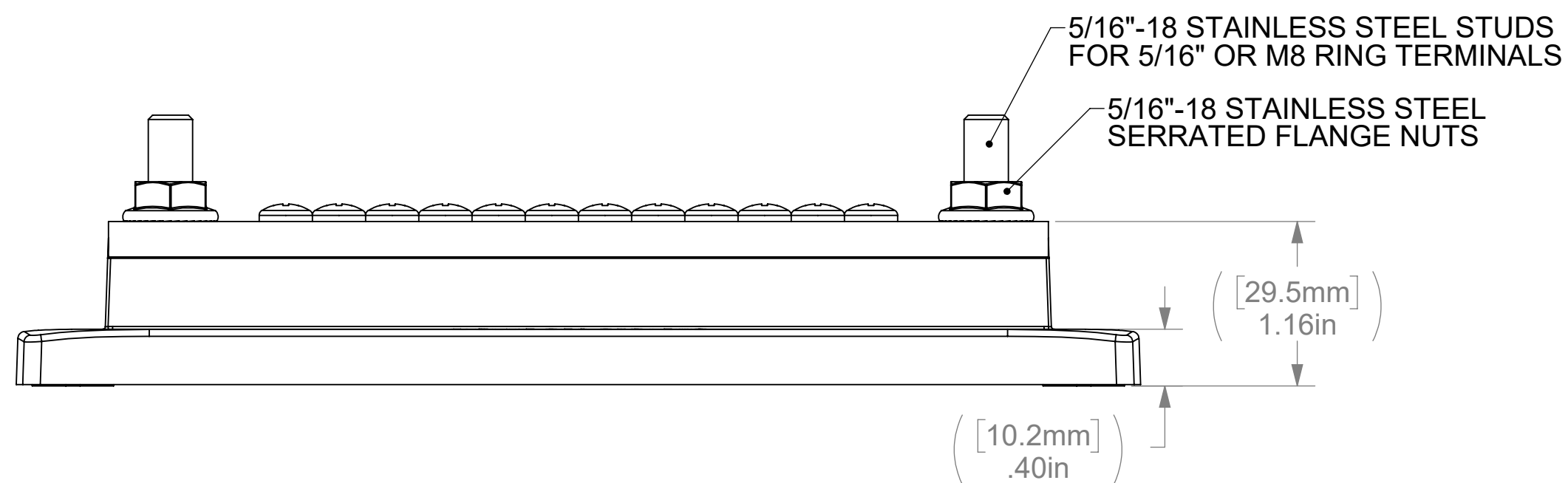
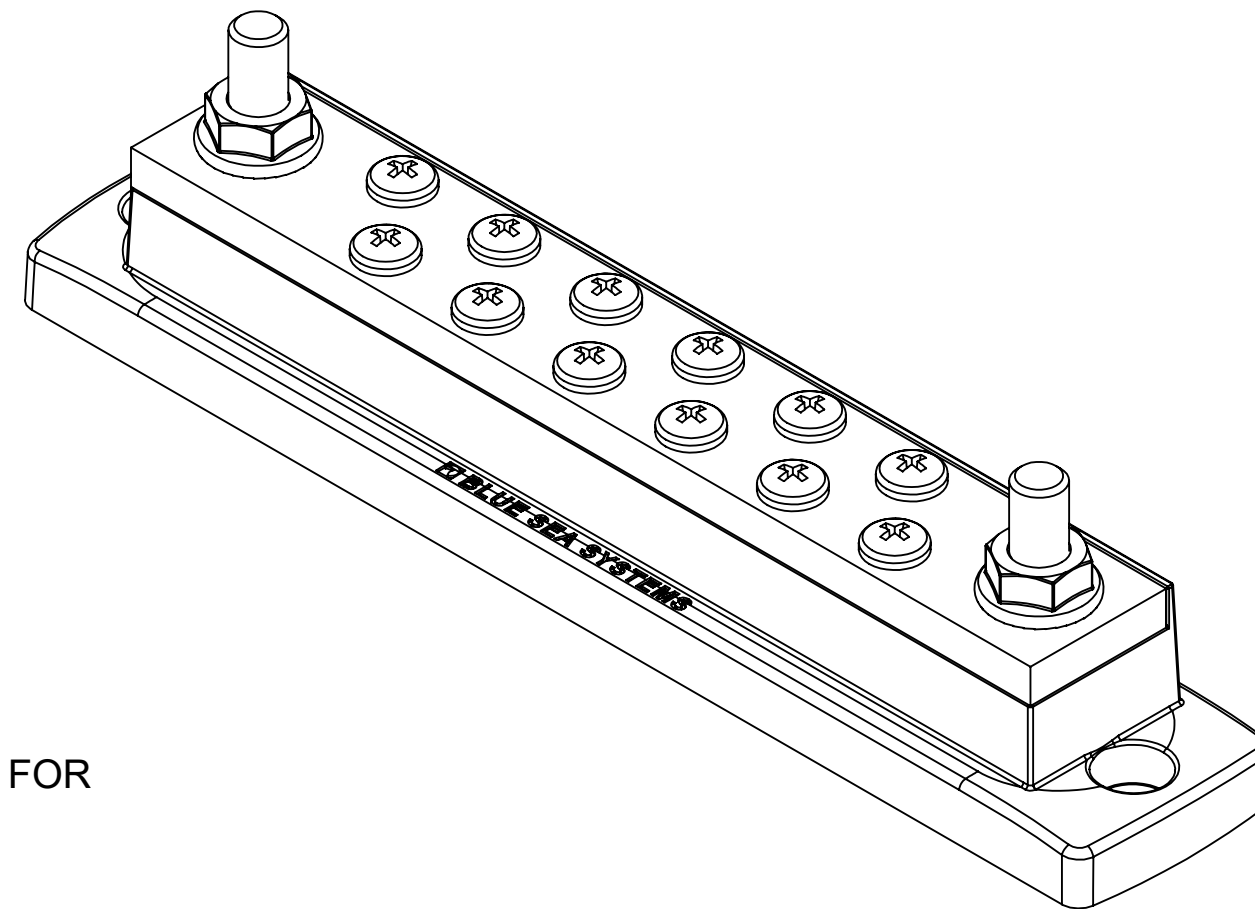
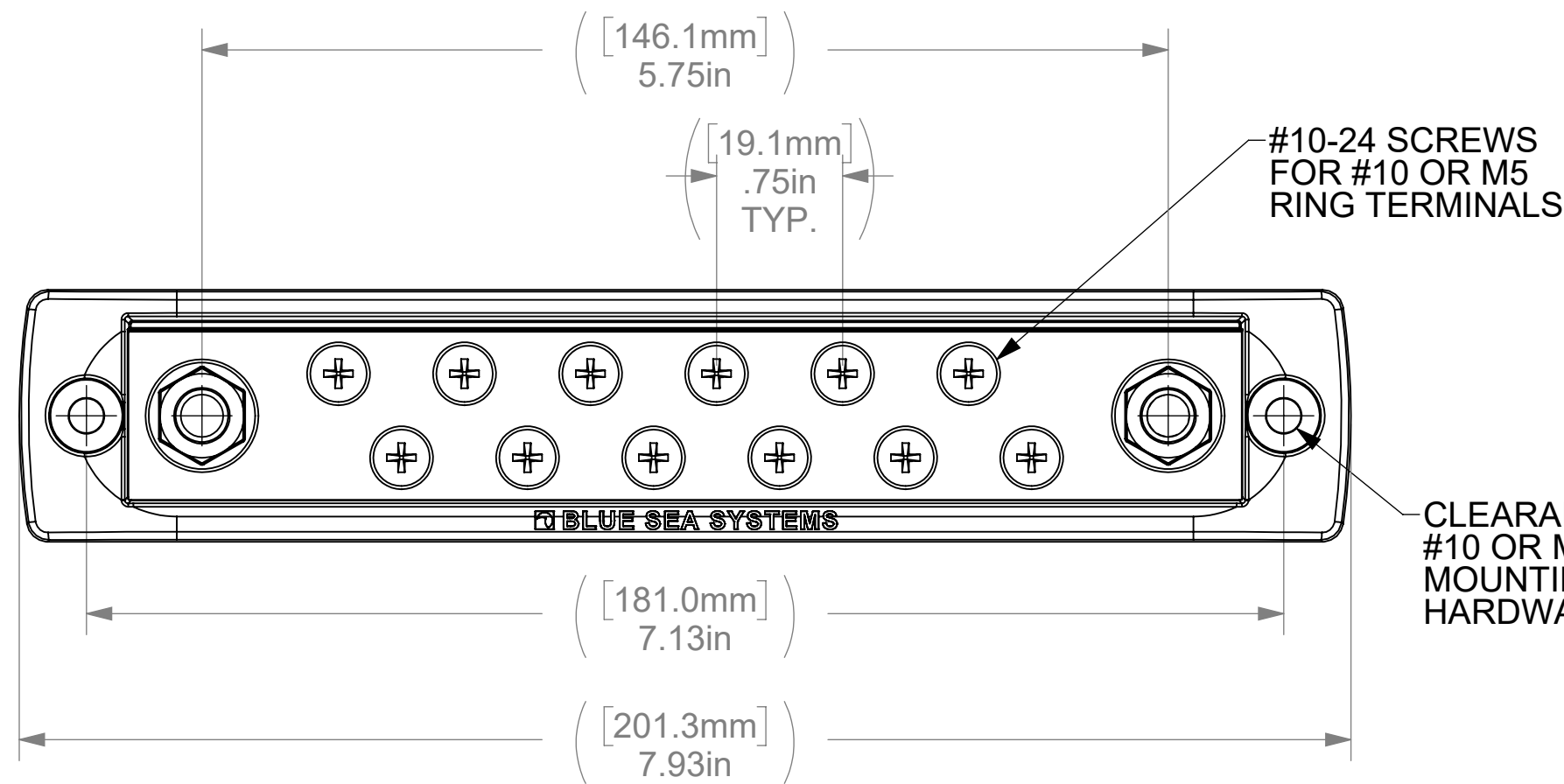

THIRD ANGLE PROJECTION



NAME	DATE
DRAWN T. DYKAS	2011.5.28
CHECKED J. RAU	2015.8.31
-	-
-	-
-	-

BLUE SEA SYSTEMS
 425 Sequoia Drive Bellingham, WA 98226
 Phone (360)738-8230 Fax (360)734-4195

CUSTOMER DRAWING
 MaxiBus 12 x 10-24 Common Bus
 Part Number 2105

SIZE	DWG. NO.	REV.
C	2105	3
SCALE 1:1	WEIGHT: --	SHEET 1 OF 1

4

3

2

1